

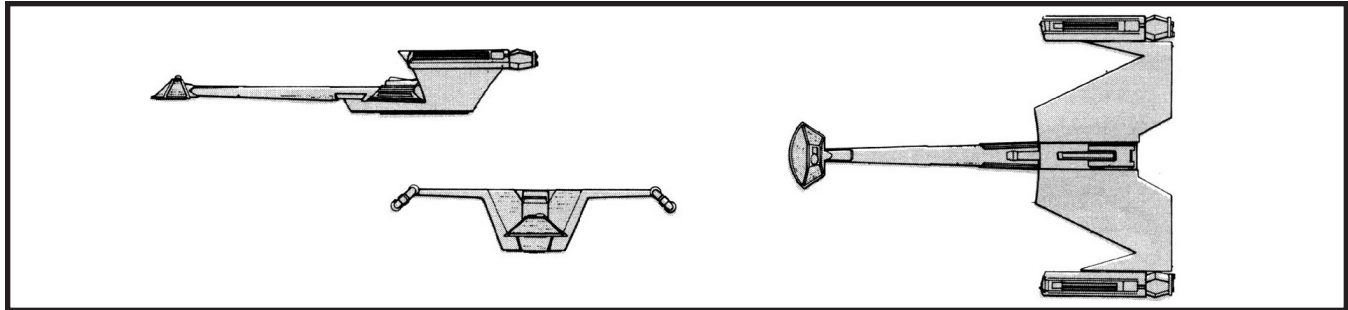

# D-18b (Fist of Reprisal) Class IX Heavy Destroyer



### Construction Data:

Model Numbers —	Type 1	Type 2	Type 3
Ship Class —	IX	IX	IX
Date Entering Service —	2282-2291	2292-2339	2342-2387
Number Constructed —	1	Refit	Refit

### Hull Data:

Superstructure Points —	23	24	24
Damage Chart —	C	C	C
Size:			
Length —	212 m	212 m	212 m
Width —	159 m	159 m	159 m
Height —	38 m	38 m	38 m
Displacement —	137,315 mt	137,800 mt	138,557 mt
Cargo:			
Cargo Units —	237 SCU	237 SCU	237 SCU
Cargo Capacity —	11,850 mt	11,850 mt	11,850 mt
Landing Capacity —	None	None	None

### Equipment Data:

Control Computer Type —	R-5m	R-5m-1	R-5m-1
Transporters:			
standard 6-person —	2	2	2
emergency 18-person —	2	2	2
cargo —	1	1	1
Cloaking Device Type —	RCC	RCC	RCC
Power Requirements —	15	15	15

### Other Data:

Crew —	265	265	265
Passengers —	20	20	20
Shuttlecraft —	12	12	12

### Engines And Power Data:

Total Power Units Available —	52	60	60
Movement Point Ratio —	3/1	3/1	3/1
Warp Engine Type —	KWE-3	KWE-3	KWE-3
Number —	2	2	2
Power Units Available —	20 ea.	20 ea.	20 ea.
Stress Chart —	J/M	J/M	J/M
Maximum Safe Cruising Speed —	Warp 8	Warp 8	Warp 8
Emergency Speed —	Warp 9	Warp 9	Warp 9
Impulse Engine Type —	RID-3	RIG-1	RIG-1
Power Units Available —	12	20	20

### Weapons And Firing Data:

Beam Weapon Type —	RB-11	RB-12	RB-12
Number —	6	6	6
Firing Arcs —	2 f/p, 2 f, 2 f/s	2 f/p, 2 f, 2 f/s	2 f/p, 2 f, 2 f/s
Firing Chart —	V	W	W
Maximum Power —	9	9	9
Damage Modifiers —			
+3	(1-10)	(1-10)	(1-10)
+2	(11-16)	(11-15)	(11-15)
+1	(17-21)	(16-20)	(16-20)
Beam Weapon Type —	RB-9	RB-11	RB-11
Number —	1	1	1
Firing Arcs —	1 a	1 a	1 a
Firing Chart —	W	V	V
Maximum Power —	6	9	9
Damage Modifiers —			
+3	(1-8)	(1-10)	(1-10)
+2	(9-16)	(11-16)	(11-16)
+1	(17-20)	(17-21)	(17-21)
Missile Weapon Type —	RP-3	RP-6	RP-11
Number —	2	2	2
Firing Arcs —	1 f, 1 a	1 f, 1 a	1 f, 1 a
Firing Chart —	Q	M	N
Power To Arm —	1	1	1
Damage —	10	18	32

### Shield Data:

Deflector Shield Type —	RSO	RSP	RSY
Shield Point Ratio —	1/3	1/3	1/3
Maximum Shield Power —	15	18	27

### Combat Efficiency:

D —	127.4	143.8	157.3
WDF —	64.8	77.7	91.9

### NOTES:

*Known Sphere Of Operation:* Triangle; Klingon border; Cardassian border

*Data Reliability:* D

*Major Data Source:* Romulan Sector Intelligence

The *First of Reprisal*, like other captured D-18 destroyers, has had a lengthy and varied combat career since it's relaunch in 2282. Directly engaging Klingon forces, the *Reprisal* continued conducting raids until she was damaged in 2291.

Initially, the *Reprisal* was scheduled for demolition but was instead refit in 2292. After her relaunch, she served along the Triangle border and conducted several long-range raids into Klingon territory. In 2339 she was seriously damaged during one of these raids and again faced the possibility of being scrapped.

However, she was again refit in 2342 and assigned to combat duty against the Klingons. She was eventually assigned to patrol duties within the Star Empire until 2374 when she was transferred to combat units preparing for operations along the Dominion/Cardassian front.

The *Reprisal* was at Romulus when the sun's collapse unexpectedly accelerated. With a non-functional warp drive, the *Reprisal* beamed aboard over 500 refugees and attempted to outrun the shock-wave. However, after nearly 4 hours of high-speed sub-light travel, the subspace shock wave eventually caught up with the *Reprisal*, damaging it beyond repair. The survivors and crew were rescued several days later and transferred to Vashti.